

# W541L260 Data Sheet



## 4-BIT MICROCONTROLLER

### **Table of Contents-**

1.	GENERAL DESCRIPTION .....	2
2.	FEATURES .....	2
3.	BLOCK DIAGRAM .....	4
4.	PIN CONFIGURATION .....	5
5.	PIN DESCRIPTION.....	6
6.	ELECTRICAL CHARACTERISTICS .....	7
6.1	Absolute Maximum Ratings .....	7
6.2	DC Characteristics .....	7
6.3	AC Characteristics.....	9
7.	APPLICATION CIRCUIT.....	10
8.	REVISION HISTORY .....	11



## 1. GENERAL DESCRIPTION

W541L260 is fully compatible with W741L260 in the terms of pin assignment and IC function except main oscillator. It is a high-performance 4-bit microcontroller ( $\mu\text{C}$ ) with an LCD driver. The device contains a 4-bit ALU, two 8-bit timers, two dividers, a  $32 \times 4$  LCD driver, and five 4-bit I/O ports (including 1 output port to drive the LEDs). There are also five interrupt sources and 8-level subroutine nesting for interrupt applications. The W541L260 has one power reduction mode to help minimize power dissipation.

The W541L260 has two oscillator circuits and can work in dual-clock or single-clock operation mode. It is suitable for remote controllers, watches and clocks, speech synthesis LSI controllers, and other products.

## 2. FEATURES

- Operating voltage: 1.2V–1.8V (LCD drive voltage: 3.0V, or 4.5V)
- Single or Dual Clock Mode
  - Single (main oscillator only) or dual clock (both main and sub-oscillator) by mask option .
  - Sub-oscillator is only 32.768 KHz crystal for dual clock mode.
  - Main oscillator is crystal or RC oscillation by mask code option .
  - Main clock : High-frequency clock (400 KHz to 1 MHz) or low-frequency clock (32.768 KHz) is selected by mask code option
- Memory
  - $2048 \times 16$  bit program ROM (including  $2\text{K} \times 4$  bit look-up table)
  - $128 \times 4$  bit data RAM (including 16 working registers)
  - $32 \times 4$  LCD data RAM
- 21 input/output pins
  - Ports for input only: 2 ports/8 pins
  - Input/output ports: 2 ports/8 pins
  - Port for output only: 1 port /4 pins (high sink current to drive LEDs)
  - MFP output pin: 1 pin (MFP)
  - Do not be floating when it is as input or output open-drain (NMOS type).
- Power-down mode
  - Hold function: no operation (except for oscillator)
  - Stop function: no operation (including main clock)



- Five types of interrupts
  - Four internal interrupts (Divider 0, Divider 1, Timer 0, Timer 1)
  - One external interrupt (Port RC)
- LCD driver output
  - 32 segment × 4 common
  - Static, 1/2 duty (1/2 bias), 1/3 duty (1/2 or 1/3 bias), 1/4 duty (1/3 bias) driving mode can be selected
  - LCD driver output pins can be used as DC output ports; selectable by code option
- MFP output pin
  - Output is software selectable as modulating or nonmodulating frequency
  - Works as frequency output specified by Timer 1
- Two built-in 14-bit clock frequency divider circuit (divider 0 and divider 1)
- Two built-in 8-bit programmable countdown timers
  - Timer 0: one of two internal clock frequencies ( $F_{osc}/4$  or  $F_{osc}/1024$ ) can be selected
  - Timer 1: includes an auto-reload function; and one of two internal clock frequencies ( $F_{osc}$  or  $F_{osc}/64$ ) can be selected or falling edge of pin RC.0 can be selected (output through MFP pin)
- Built-in 18/14-bit watchdog timer selectable for system reset
- Powerful instruction set: 115 instructions
- 8-level subroutine (include interrupt) nesting
- Up to 4  $\mu$ S instruction cycle (with 1 MHz operating frequency)
- Packaged in 80-pin QFP

### 3. BLOCK DIAGRAM

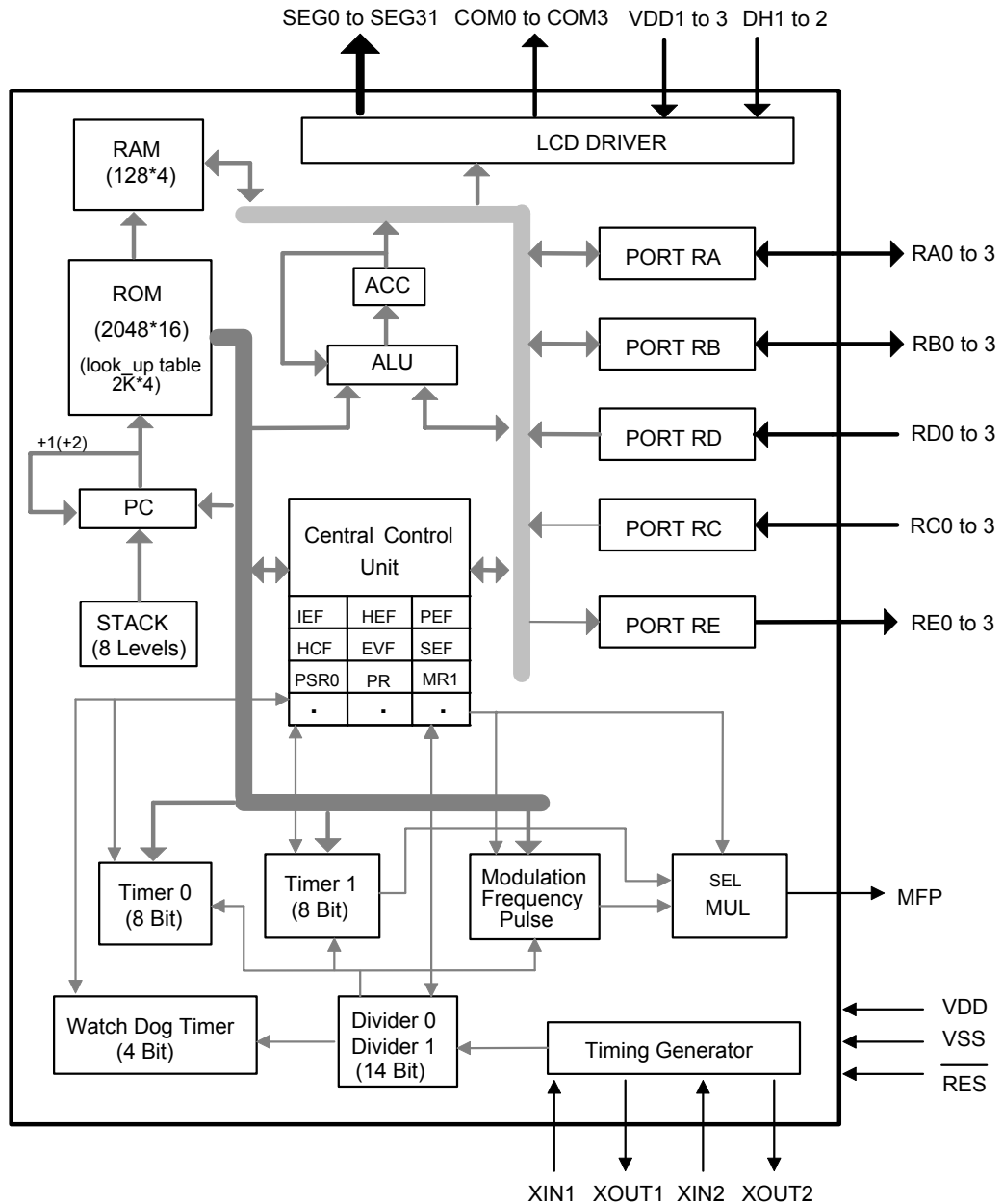



4. PIN CONFIGURATION

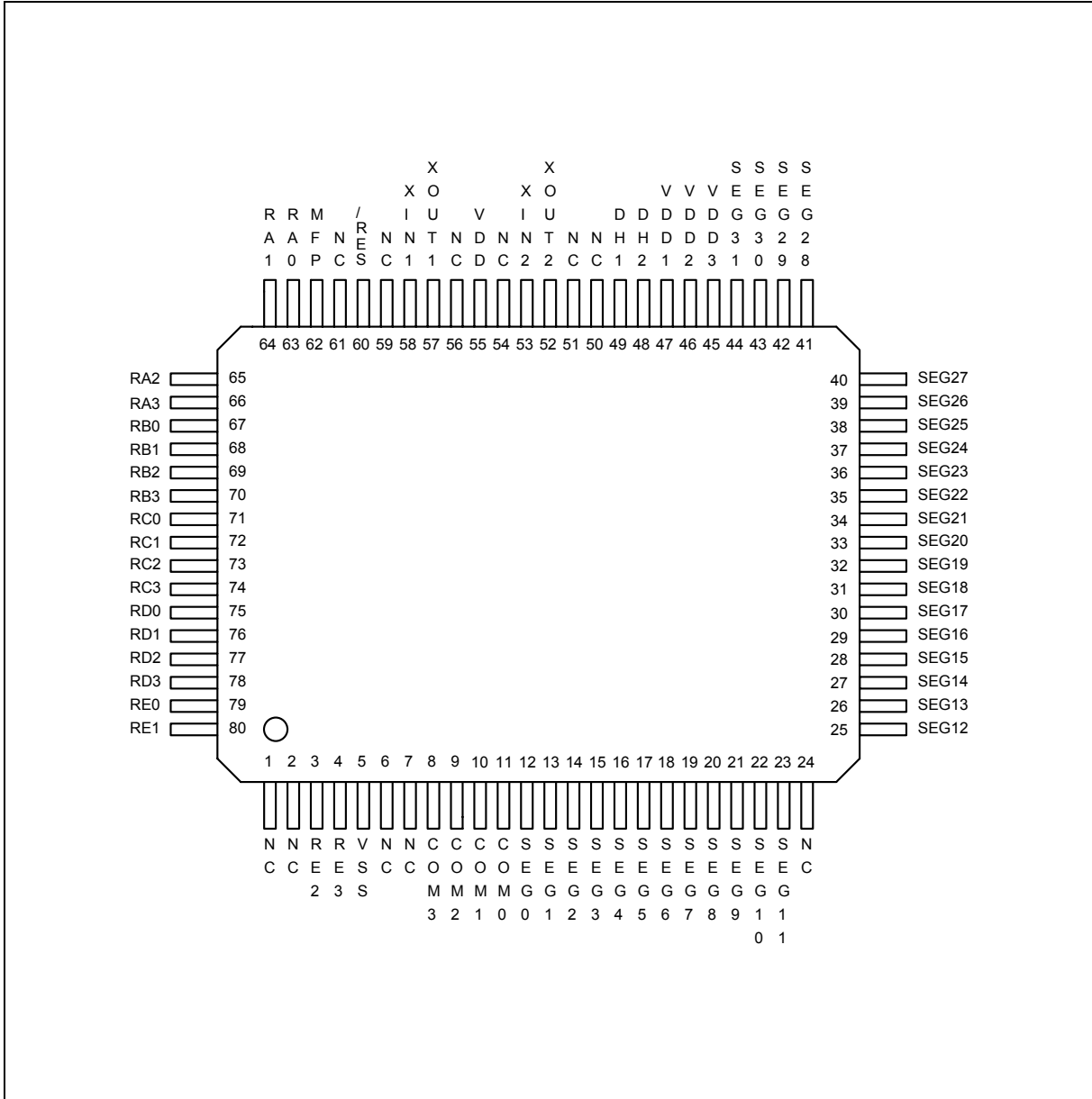

## 5. PIN DESCRIPTION

SYMBOL	I/O	FUNCTION																									
XIN1	I	Input pin for oscillator. Connected to crystal or resistor to generate system clock by code option. External 10~20pF capacitor uses to get accurate freq in crystal mode.																									
XOUT1	O	Output pin for oscillator. Connected to crystal or resistor to generate system clock by code option. 20pF capacitor is built in internal for crystal mode.																									
XIN2	I	Input pin for sub-oscillator. Connected to a 32.768 KHz crystal. External 10~20pF capacitor uses to get accurate freq in crystal mode.																									
XOUT2	O	Output pin for sub-oscillator. Connected to a 32.768 KHz crystal. 20pF capacitor is built in internal for crystal mode.																									
RA0~RA3	I/O	Input/Output port. Input/output mode specified by port mode 1 register (PM1).																									
RB0~RB3	I/O	Input/Output port. Input/output mode specified by port mode 2 register (PM2).																									
RC0~RC3	I	4-bit port for input only. Each pin has an independent interrupt capability. And build-in schmitt trigger.																									
RD0~RD3	I	4-bit port for input only.																									
RE0~RE3	O	Output port only. This port provides high sink current to drive LEDs.																									
MFP	O	Output pin only. This pin can output modulating or nonmodulating frequency, or Timer 1 clock output specified by mode register 1 (MR1).																									
$\overline{\text{RES}}$	I	System reset pin with pull-high resistor.																									
SEG0~SEG31	O	LCD segment output pins. Can also be used as DC output ports specified by code option.																									
COM0~COM3	O	LCD common signal output pins. <table border="1" data-bbox="526 1423 1117 1633"> <thead> <tr> <th></th> <th>Static</th> <th>1/2 Duty</th> <th>1/3 Duty</th> <th>1/4 Duty</th> </tr> </thead> <tbody> <tr> <td>COM0</td> <td>Used</td> <td>Used</td> <td>Used</td> <td>Used</td> </tr> <tr> <td>COM1</td> <td>Not Used</td> <td>Used</td> <td>Used</td> <td>Used</td> </tr> <tr> <td>COM2</td> <td>Not Used</td> <td>Not Used</td> <td>Used</td> <td>Used</td> </tr> <tr> <td>COM3</td> <td>Not Used</td> <td>Not Used</td> <td>Not Used</td> <td>Used</td> </tr> </tbody> </table> <p>The LCD alternating frequency can be selected by code option.</p>		Static	1/2 Duty	1/3 Duty	1/4 Duty	COM0	Used	Used	Used	Used	COM1	Not Used	Used	Used	Used	COM2	Not Used	Not Used	Used	Used	COM3	Not Used	Not Used	Not Used	Used
	Static	1/2 Duty	1/3 Duty	1/4 Duty																							
COM0	Used	Used	Used	Used																							
COM1	Not Used	Used	Used	Used																							
COM2	Not Used	Not Used	Used	Used																							
COM3	Not Used	Not Used	Not Used	Used																							
DH1, DH2	I	Connection terminals for voltage doubler (halver) capacitor.																									
VDD1, VDD2 VDD3	I	Positive (+) supply voltage terminal. Refer to Functional Description.																									
VDD	I	Positive power supply (+).																									
VSS	I	Negative power supply (-).																									



## 6. ELECTRICAL CHARACTERISTICS

### 6.1 Absolute Maximum Ratings

PARAMETER	RATING	UNIT
Supply Voltage to Ground Potential	-0.3 to +7.0	V
Applied Input/Output Voltage	-0.3 to +7.0	V
Power Dissipation	120	mW
Ambient Operating Temperature	0 to +70	°C
Storage Temperature	-55 to +150	°C

Note: Exposure to conditions beyond those listed under Absolute Maximum Ratings may adversely affect the life and reliability of the device.

### 6.2 DC Characteristics

(V<sub>DD</sub>-V<sub>SS</sub> = 1.5V, F<sub>osc</sub> = 32.768 KHz, T<sub>A</sub> = 25° C; unless otherwise specified)

PARAMETER	SYM.	CONDITIONS	MIN.	TYP.	MAX.	UNIT
Op. Volt ( Crystal type)	VDD1	High-frequency Oscillation	1.35	-	1.8	V
Op. Volt ( RC type)	VDD2	High-frequency Oscillation	1.2	-	1.8	V
Op. Volt ( RC, Crystal)	VDD3	Low-frequency Oscillation	1.2	-	1.8	V
Op. Current (RC Type)	IOP2	No load (Ext-V) In dual-clock normal operation	-	100	400	μA
Op. Current (Crystal Type)	IOP3	No load (Ext-V) In dual-clock slow operation and Fm is stopped	-	8.5	20	μA
Hold Current (RC Type)	IHM2	Hold mode No load (Ext-V) In dual-clock normal operation	-	60	100	μA
Hold Current (Crystal Type)	IHM3	Hold mode No load (Ext-V) In dual-clock slow operation and Fm is stopped	-	4.0	6	μA
Stop Current (Crystal type)	ISM1	Stop mode No load (Ext-V) In dual-clock normal operation	-	4.0	6	μA
Stop Current (Crystal type)	ISM2	Stop mode No load (Ext-V) In single-clock operation	-	0.1	2	μA



DC Characteristics, continue

PARAMETER	SYM.	CONDITIONS	MIN.	TYP.	MAX.	UNIT
Input Low Voltage	V <sub>IL</sub>	-	V <sub>SS</sub>	-	0.3 V <sub>DD</sub>	V
Input High Voltage	V <sub>IH</sub>	-	0.7 V <sub>DD</sub>	-	V <sub>DD</sub>	V
MFP Output Low Voltage	V <sub>ML</sub>	I <sub>OL</sub> = 0.9 mA	-	0.1	0.3	V
MFP Output High Voltage	V <sub>MH</sub>	I <sub>OH</sub> = 0.75 mA	1.2	1.4	-	V
Port RA, RB Output Low Voltage	V <sub>ABL</sub>	I <sub>OL</sub> = 1.0 mA	-	0.2	0.3	V
Port RA, RB Output High Voltage	V <sub>ABH</sub>	I <sub>OH</sub> = 0.5 mA	1.2	1.4	-	V
LCD Supply Current	I <sub>LCD</sub>	All Seg. ON	-	-	6	μA
SEG0–SEG31 Sink Current (Used as LCD Output)	I <sub>OL1</sub>	V <sub>OL</sub> = 0.05V V <sub>LCD</sub> = 0.0V	6	12	-	μA
SEG0–SEG31 Drive Current (Used as LCD Output)	I <sub>OH1</sub>	V <sub>OH</sub> = 4.45V V <sub>LCD</sub> = 4.5V	1.5	12	-	μA
Segment Output Low Voltage (Used as DC Output)	V <sub>SL</sub>	I <sub>OL</sub> = 150 μA	-	0.1	0.15	V
Segment Output High Voltage (Used as DC Output)	*V <sub>SH</sub>	I <sub>OH</sub> = 1 μA	1.05	1.4	-	V
Port RE Sink Current	I <sub>EL</sub>	V <sub>OL</sub> = 0.3V	2	-	-	mA
Port RE Source Current	I <sub>EH</sub>	V <sub>OH</sub> = 1.2V	0.35	0.45	-	mA
Input Port Pull-up Resistor	R <sub>CD</sub>	Port RC, RD	200	1000	1500	KΩ
$\overline{\text{RES}}$ Pull-up Resistor	R <sub>RES</sub>	-	200	500	1500	KΩ

Note : \*V<sub>SH</sub>: Its ability is based on LCD power connected to 0.1 uF capacitor.



### 6.3 AC Characteristics

(V<sub>DD</sub>-V<sub>SS</sub> = 1.5V, T<sub>A</sub> = 25° C, unless otherwise specified)

PARAMETER	SYM.	CONDITIONS	MIN.	TYP.	MAX.	UNIT
Op. Frequency	FOSC	RC type	-	-	1000	KHz
		Crystal type (Option low speed type only)	-	32.768	-	
Frequency Deviation by Voltage Drop for RC Oscillator	$\frac{\Delta f}{f}$	$\frac{f(1.5V) - f(1.2V)}{f(1.5V)}$	-	-	10	%
Oscillator Start-up Time	T <sub>S</sub>	V <sub>DD</sub> =1.2 V, FOSC=32.768 KHz	-	1	2	S
Instruction Cycle Time	T <sub>I</sub>	One machine cycle	-	4/FOSC	-	mS
Reset Active Width	T <sub>RAW</sub>	FOSC = 32.768 KHz	1	-	-	μS
Interrupt Active Width	T <sub>IAW</sub>	FOSC = 32.768 KHz	1	-	-	μS

## 7. APPLICATION CIRCUIT

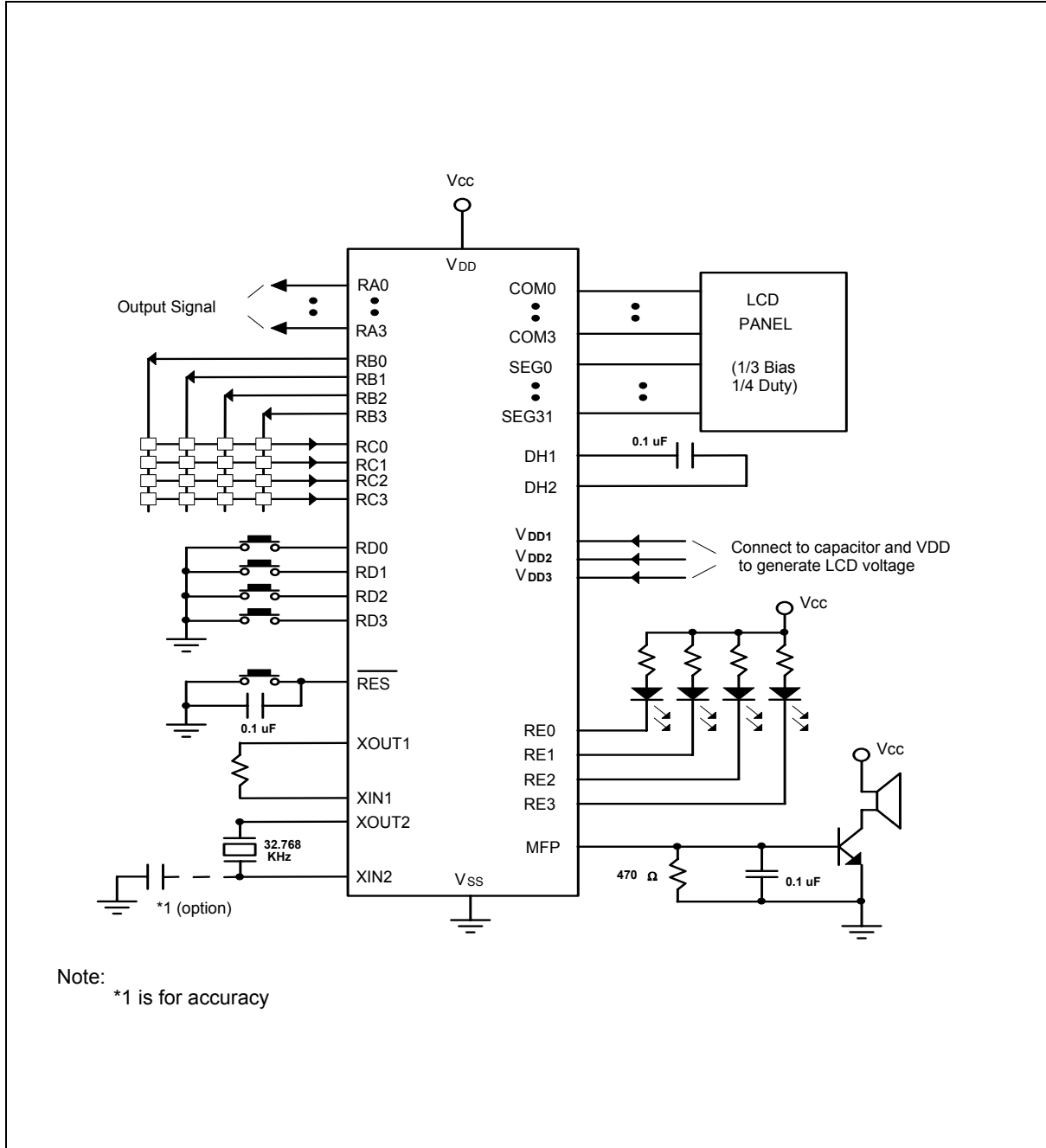



## 8. REVISION HISTORY

VERSION	DATE	DESCRIPTION
A2	-	Note: Recommend working voltage range for Hi freq X al mode (L series)
A3	-	Note: RC is built-in schmitt trigger
A4	May 29, 2003	Note: Do not be floating when it is as input or output open-drain (NMOS type)



**Headquarters**  
 No. 4, Creation Rd. III,  
 Science-Based Industrial Park,  
 Hsinchu, Taiwan  
 TEL: 886-3-5770066  
 FAX: 886-3-5665577  
<http://www.winbond.com.tw/>

**Taipei Office**  
 9F, No.480, Rueiguang Rd.,  
 Neihu District, Taipei, 114,  
 Taiwan, R.O.C.  
 TEL: 886-2-8177-7168  
 FAX: 886-2-8751-3579

**Winbond Electronics Corporation America**  
 2727 North First Street, San Jose,  
 CA 95134, U.S.A.  
 TEL: 1-408-9436666  
 FAX: 1-408-5441798

**Winbond Electronics Corporation Japan**  
 7F Daini-ueno BLDG, 3-7-18  
 Shinyokohama Kohoku-ku,  
 Yokohama, 222-0033  
 TEL: 81-45-4781881  
 FAX: 81-45-4781800

**Winbond Electronics (Shanghai) Ltd.**  
 27F, 2299 Yan An W. Rd. Shanghai,  
 200336 China  
 TEL: 86-21-62365999  
 FAX: 86-21-62365998

**Winbond Electronics (H.K.) Ltd.**  
 Unit 9-15, 22F, Millennium City,  
 No. 378 Kwun Tong Rd.,  
 Kowloon, Hong Kong  
 TEL: 852-27513100  
 FAX: 852-27552064

*Please note that all data and specifications are subject to change without notice.  
 All the trade marks of products and companies mentioned in this data sheet belong to their respective owners.*